

RoHS

包装图

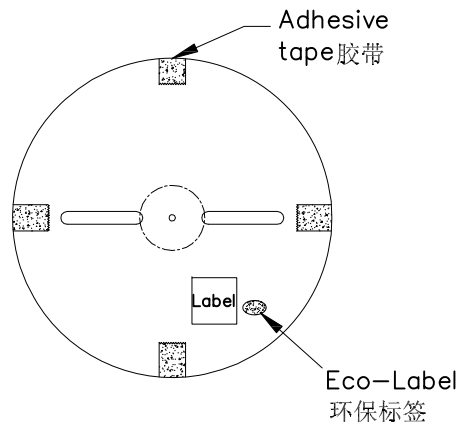

Note 注解:

1.Quantity 数量:

15K PCS/REEL 一卷15K/PCS

10 REEL/BOX 一箱10卷

150K PCS/BOX 一箱150K/PCS

2.Each reel and outer box must be labeled and Eco-Label Respectively labeled

每盘和外箱都必须有标签及环保标签分别标示

3.Terminal winding direction as shown 端子缠绕方向如左图所示

4.There shall be no dirt such as deformation phenomenon, Mantissa box fillers must be used

每箱不可有脏污, 变形现象, 尾数箱必须用填充物

5.Carton material K=K, Carton thickness : 6±1mm 纸箱材质: K=K 纸箱厚度: 6~7mm

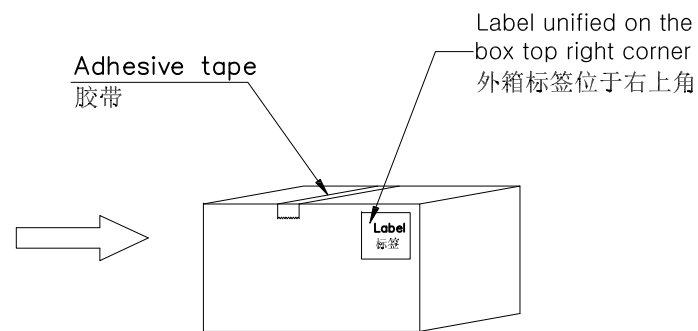
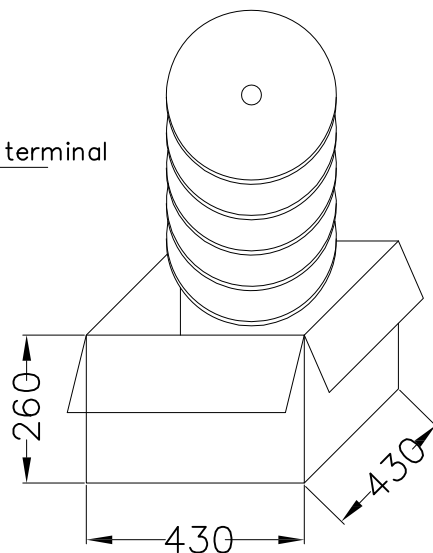
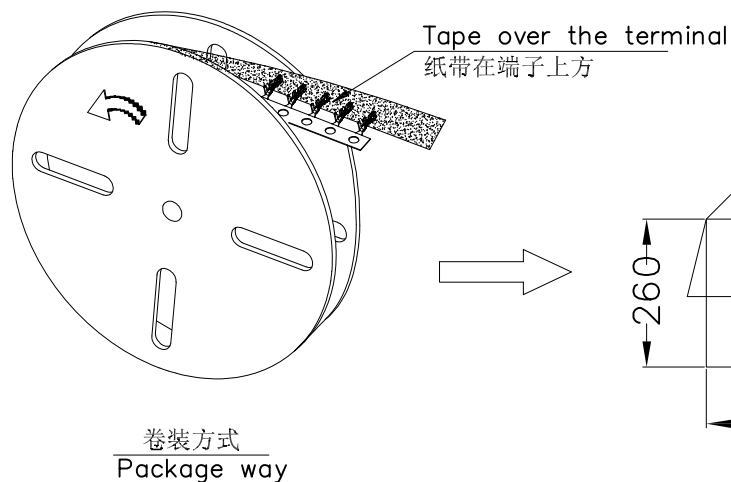

DATE	REV	ECN NO.	DESCRIPTION	MODIFY	APPROVAL
1					
2					
3					
4					

GENERAL TOLERANCE	
.X	±0.30
.XX	±0.20
.XXX	±0.10
X.	±0.2°

	东莞市国亚电子有限公司 Dong Guan Guo Ya Connectors co., Ltd.			
	APPROVAL	CHECK	DRAWN	DATE
	Yangzhengguo	Yangzhengyi	Lvtiansheng	2016/08/26

PART NO. : 1002T-PXX				
TITLE : 1.00mm Terminal Packing				
UNIT	SCALE	SHEET	REV	NUMBER
mm	1:1	1/1	A0	A-014

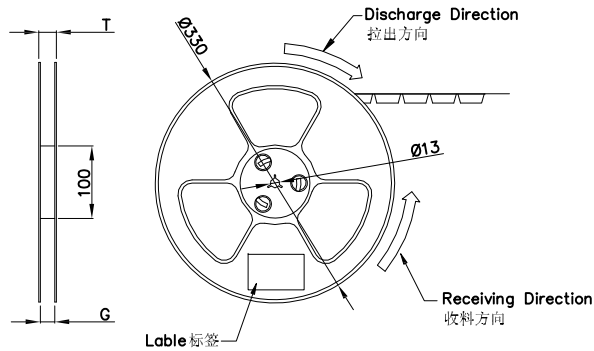
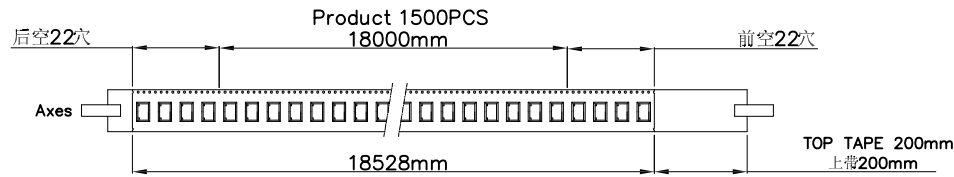

COVER TAPE PEEL STRENGTH: 20~120g
上带剥离力量20~120g
速度 PEEL SPEED: 300mm/minute

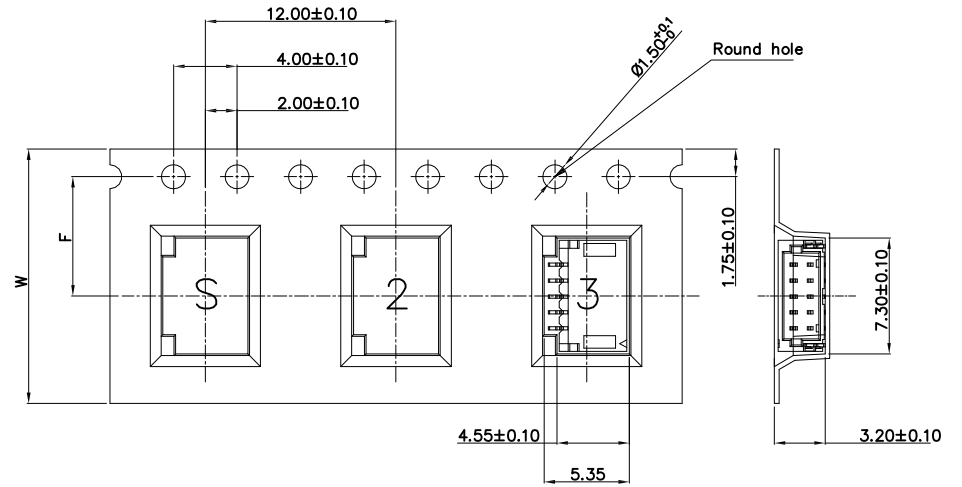
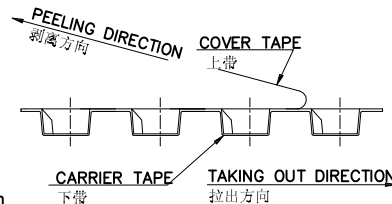

WIDTH=16mm

Vacuum packing
真空包装
Drier
干燥剂2包10g

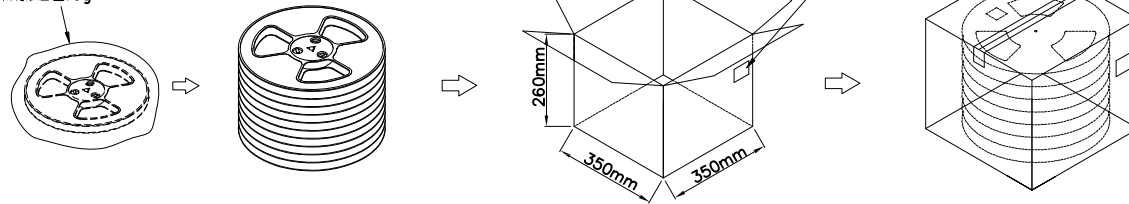

Note:

- Carrier Camber Is Within 1mm In 100mm ; 带长100mm 内容许弯曲度1mm
- 10 Sprocket Hole Pitch Cumulative Tolerance±0.2MM ; 圆孔十个孔距离累计允许公差为±0.2mm
- Material for PS ; 材质为PS材质 ; Color 颜色: Natural 透明色
- brace 护带; Color 颜色: Natural 透明色
- Thickness=0.30±0.05 ; 材料厚度为0.30±0.05mm
- Carton material 纸箱材质: K=K; Carton Thickness 纸箱厚度: 6~7mm

Part No.	W	S	F	T (MAX)	G(MAX)	REEL /PCS	CARTON /R	CARTON /PCS
ZD1002WRS-05HF	16	/	7.50	22.50	16.50	1500	11R	16500

GENERAL TOLERANCE	
.X	±0.30
.XX	±0.20
.XXX	±0.10
X°	±0.2°



东莞市国亚电子有限公司
Dong Guan Guo Ya Connectors co., Ltd.

PART NO. :
PPN: 1002WRS-05-LPSN
CTN: ZD1002WRS-05HF

TITLE :
1.00mm Connectors SMT 90° Packing

APPROVAL	CHECK	DRAWN	DATE
Yangzhengguo	Yangzhengyi	Lvtiansheng	2016/08/26

UNIT	SCALE	SHEET	REV	NUMBER
mm	1:1	1/1	A0	A-205

DATE	REV	ECN NO.	DESCRIPTION	MODIFY	APPROVAL
1					
2					
3					
4					

